

TURPEHEU



Conforama

NOTICE DE MONTAGE
 ASSEMBLING INSTRUCTIONS
 ISTRUZIONI DI MONTAGGIO
 MONTAGEANLEITUNG
 ISTRUÇÕES DE MONTAGEM
 MANUAL DE MONTAJE
 INSTRUCJA MONTAZU

Vaisselleier PYRENEES II

03-05/2005

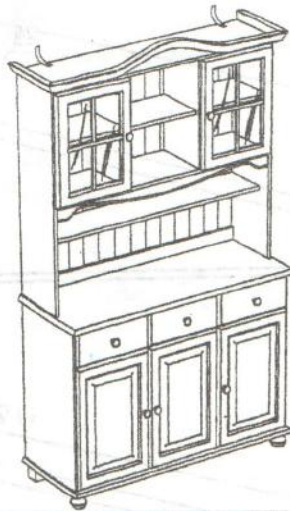
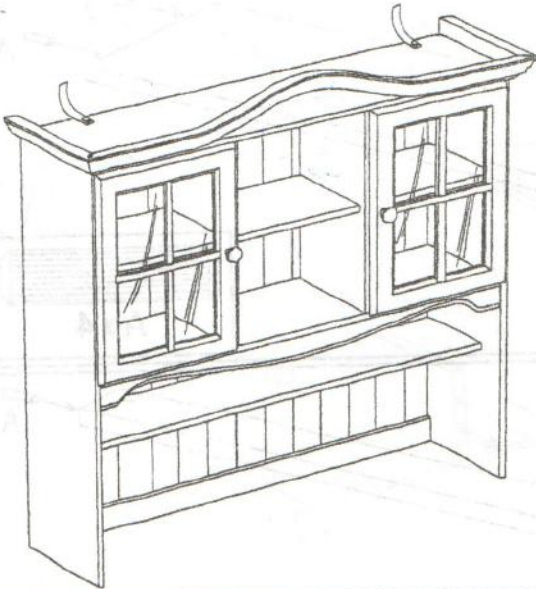

90 MIN

x2

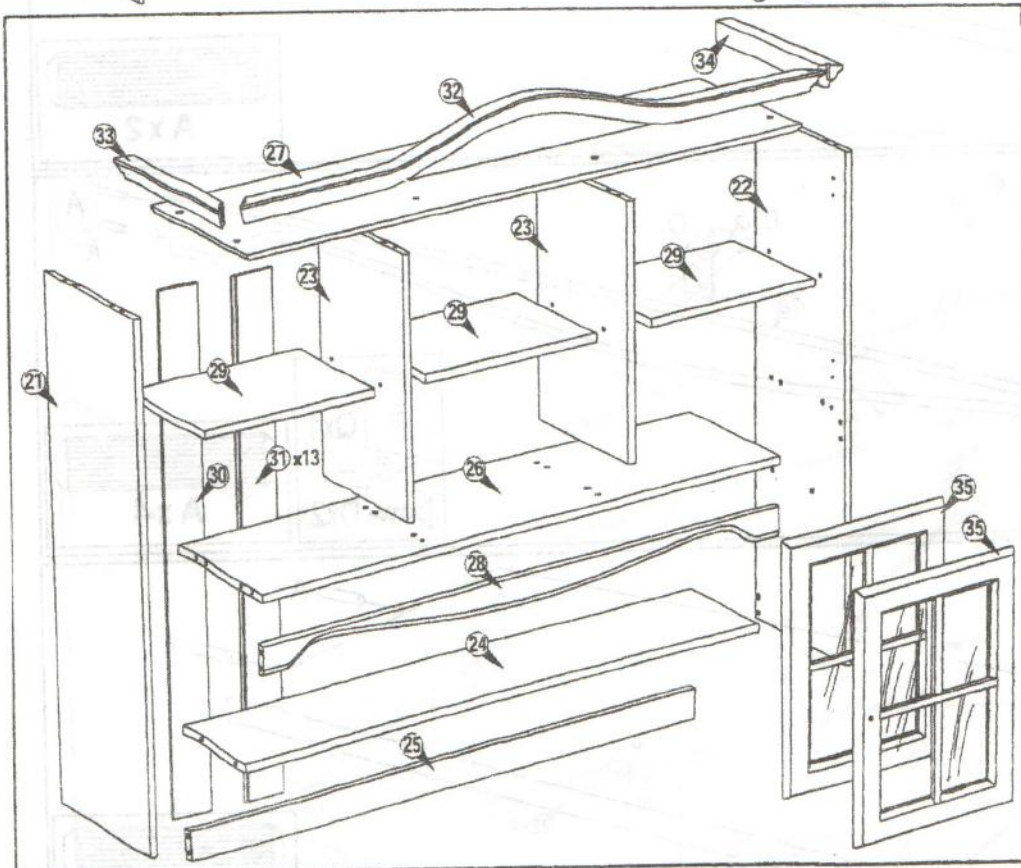

AVANT DE COMMENCER, SE
 REPORTER AUX CONSEILS
 DE MONTAGE EN ANNEXE

BEFORE STARTING, REFER
 TO THE ASSEMBLING ADVICE
 IN ANNEX

AVANTI DI COMMINCIARE,
 RIPORTATE AGLI CONSIGLI DI
 MONTAGGIO

VOR DIE MONTAGE, BITTE
 BEILIEGENDE ANWEISUNGEN
 FOLGEN

ANTES DE COMEÇAR, ADIAR-
 SE AOS CONSELHOS DE
 MONTAGEM EM ANEXO

ANTES DE EMPEZAR
 CONSULTE LOS CONSEJOS
 PARA EL MONTAJE

PRZED ROZPOCZECIEM
 ZAPOZNAC SIE ZALACZONA
 INSTRUCJA MONTAZU

Ax26 	Cx4 	Dx44 	Ex6 	Fx6 	Gx12 	Hx46 	Ix2 	Jx2
Kx4 	Lx12 	Nx1 	Ox2 	Px2 	Qx5 	Rx2 		

1

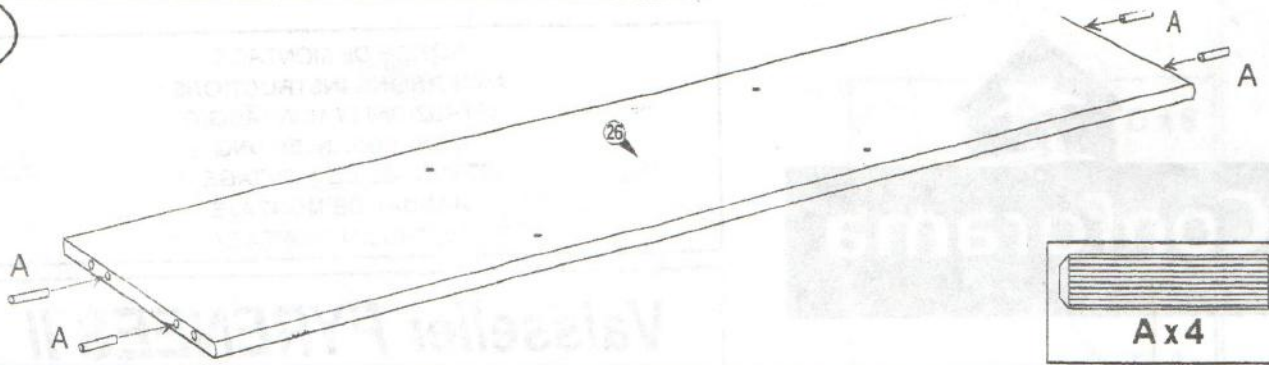

2

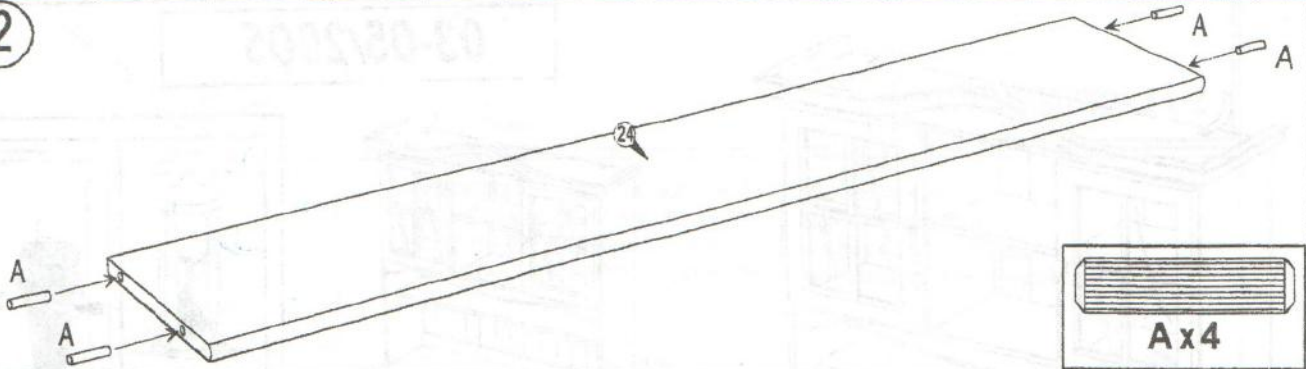

3

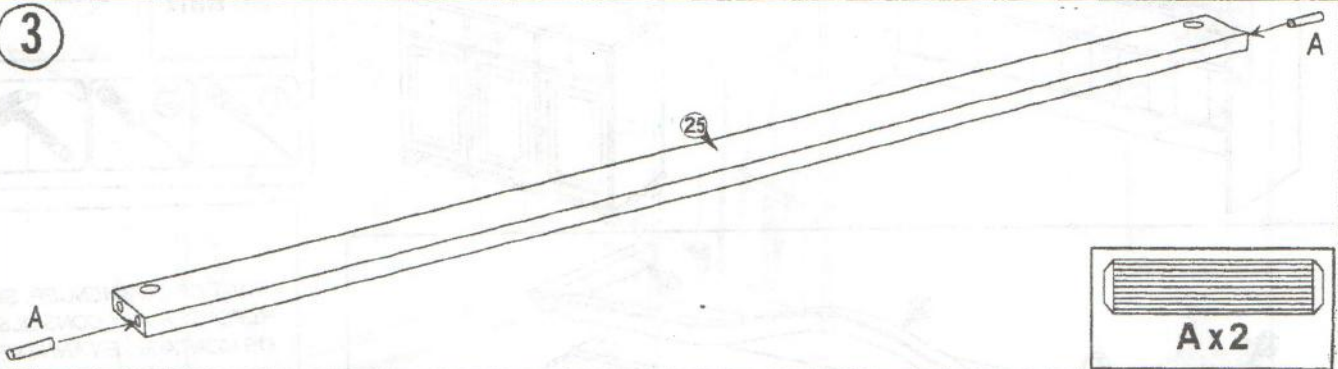

4

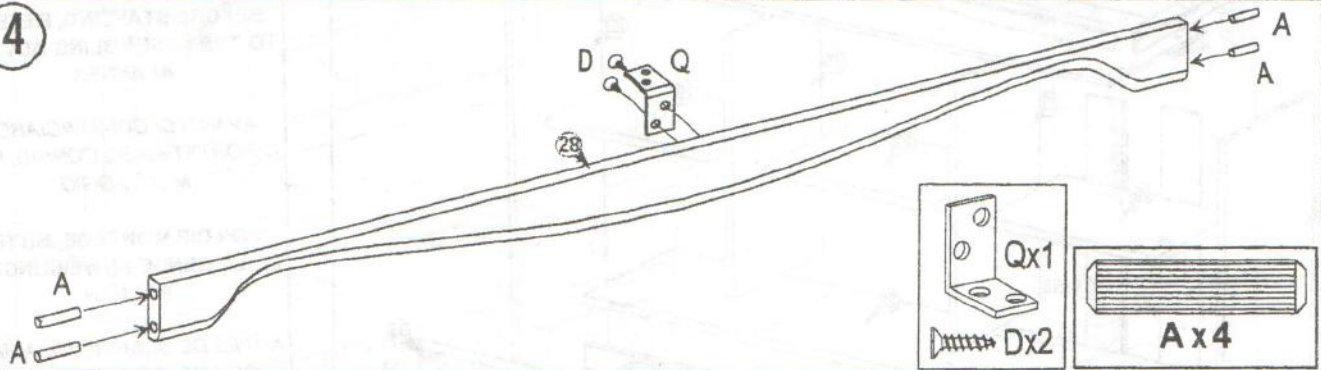

5

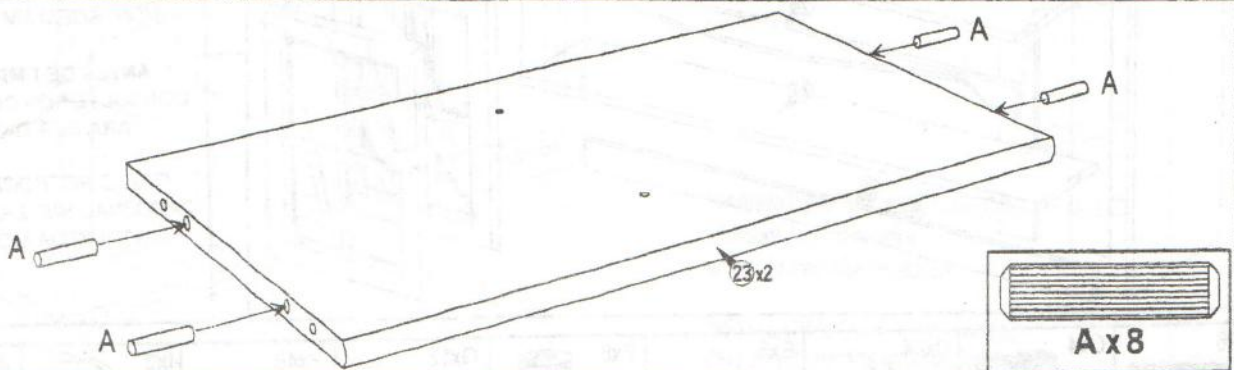

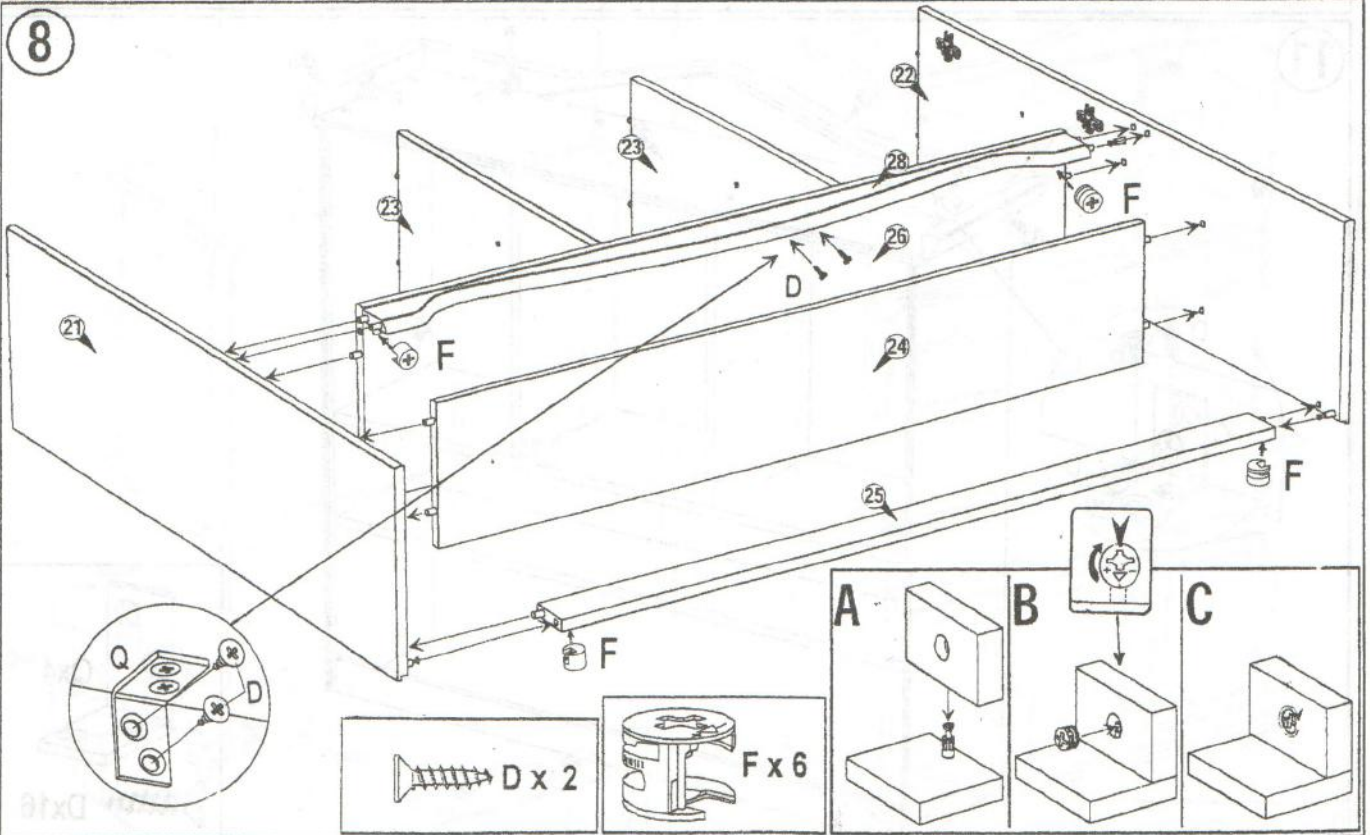
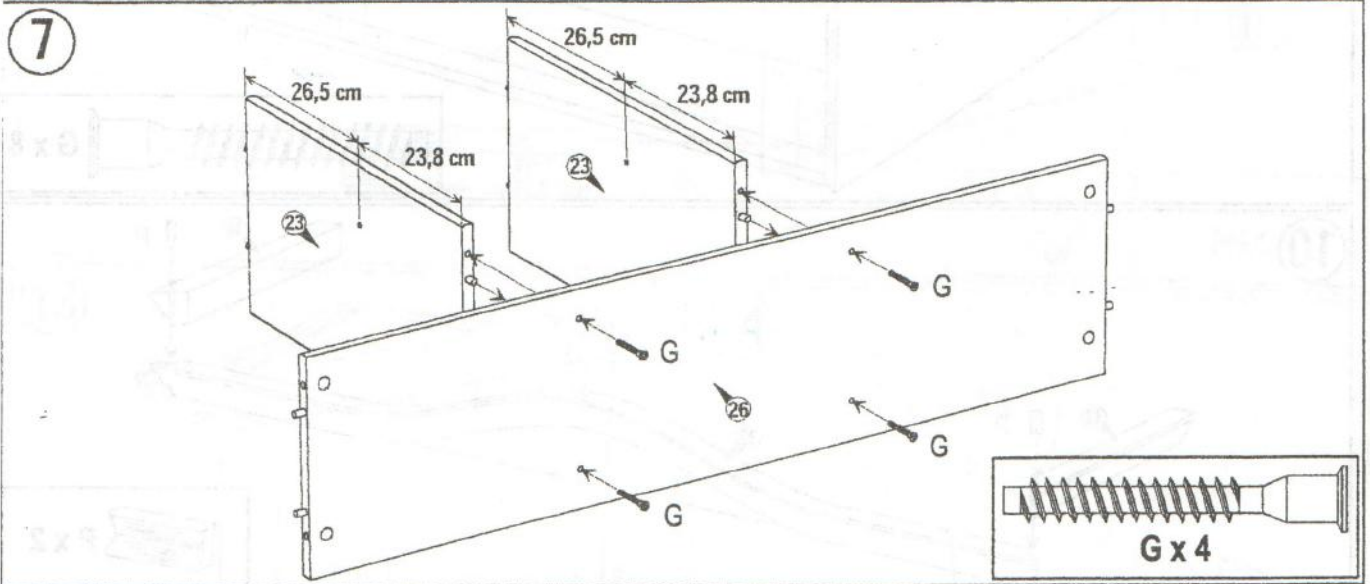
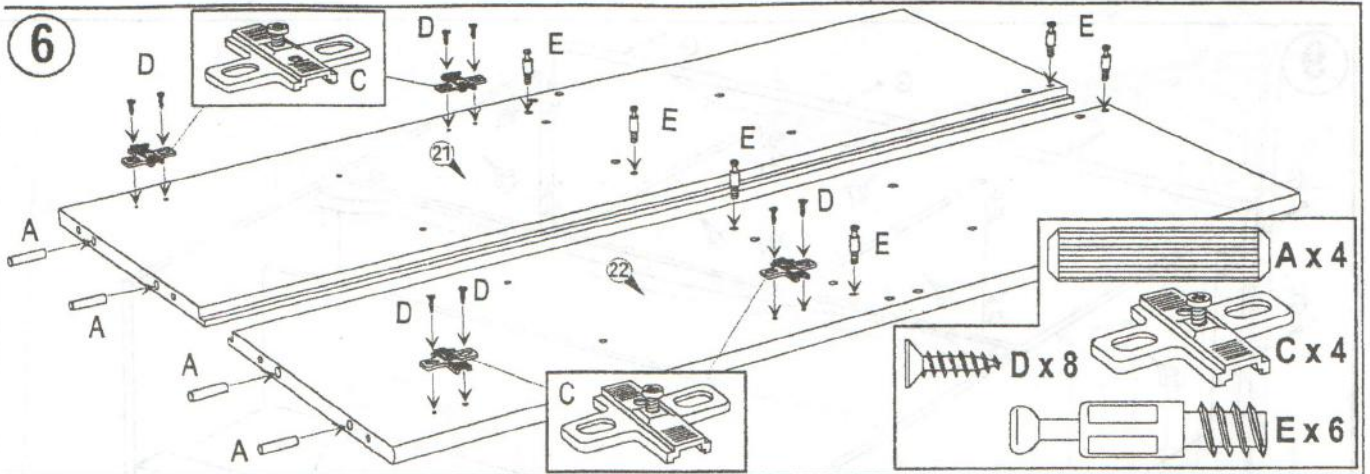

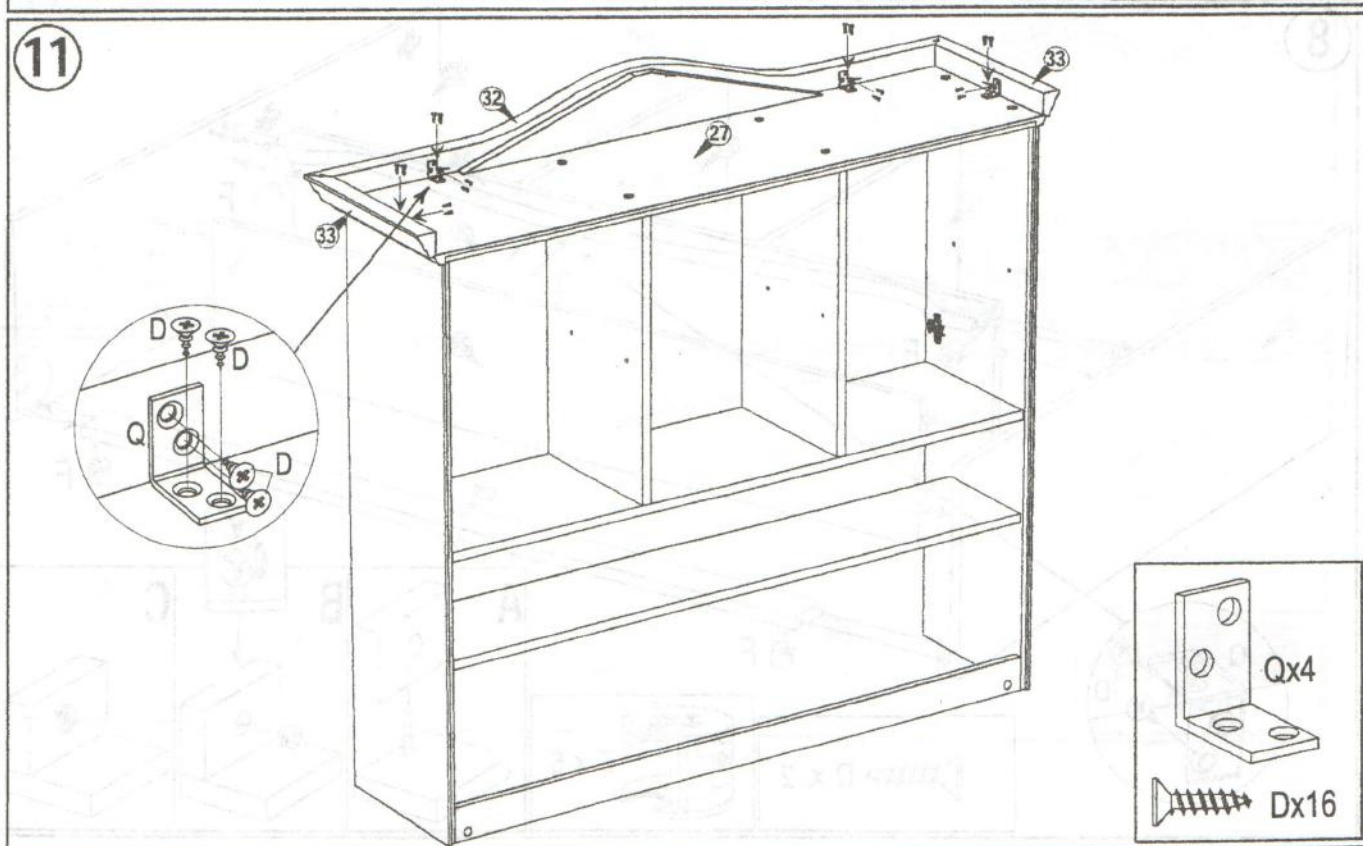
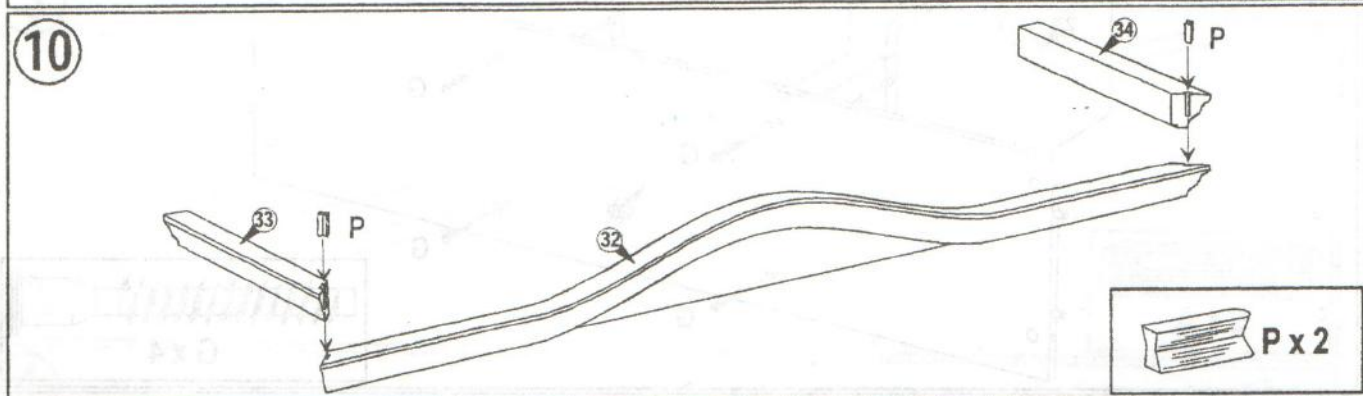
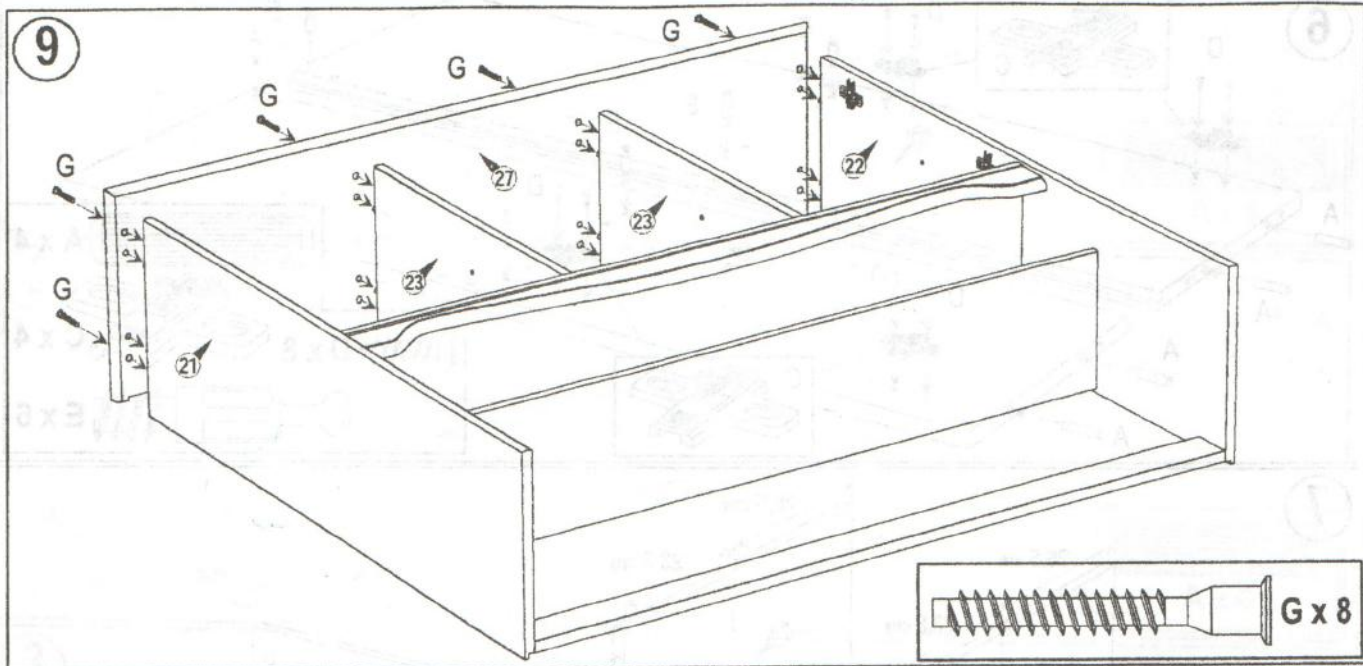

12

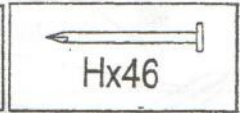
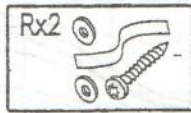
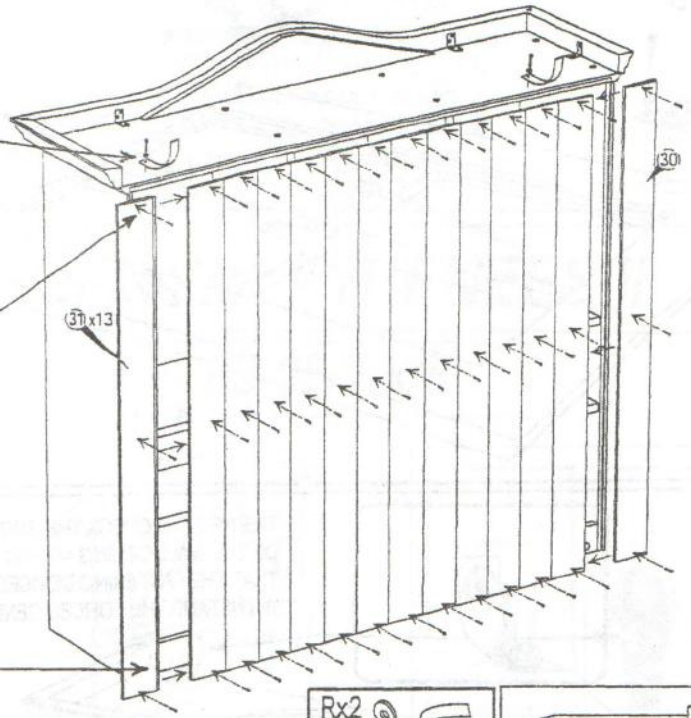
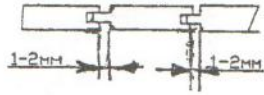
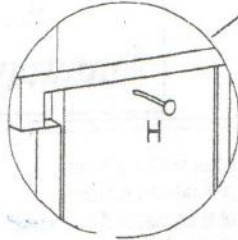
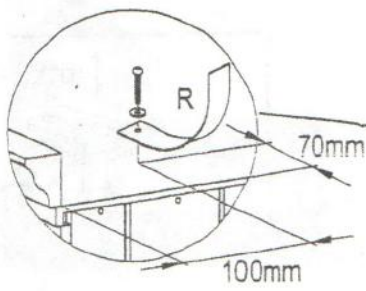

13

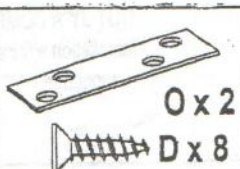
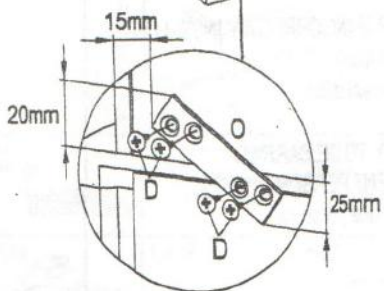
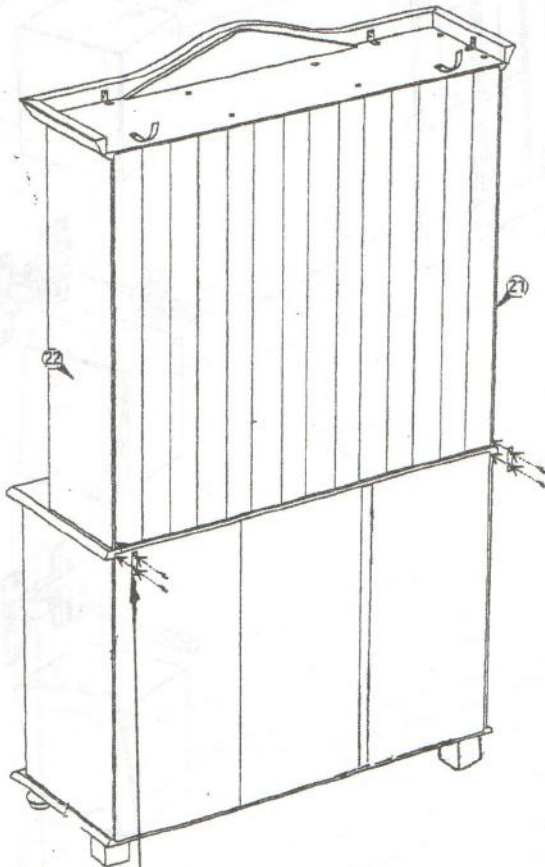

14

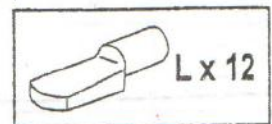
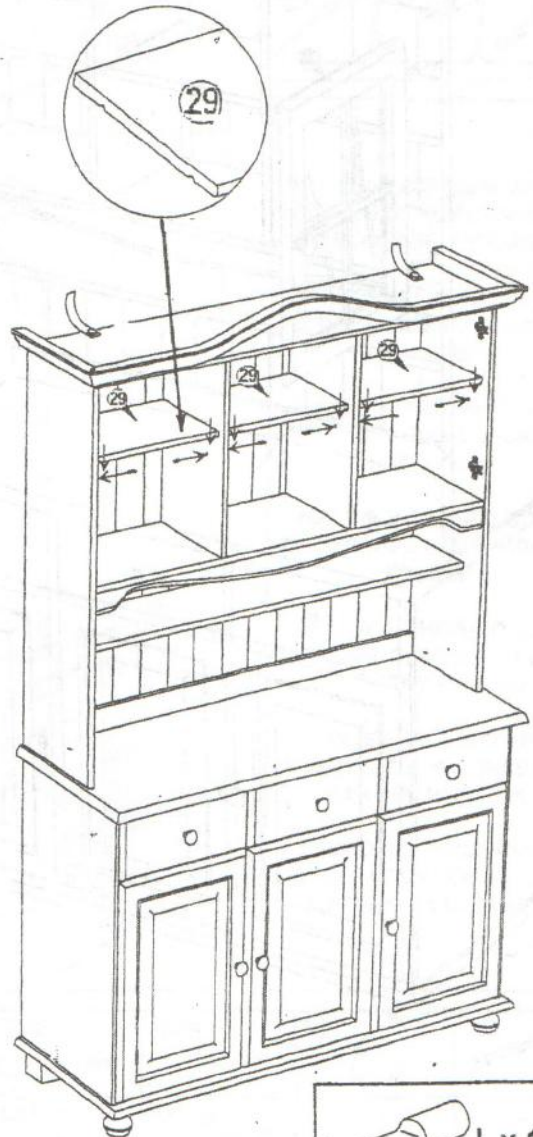

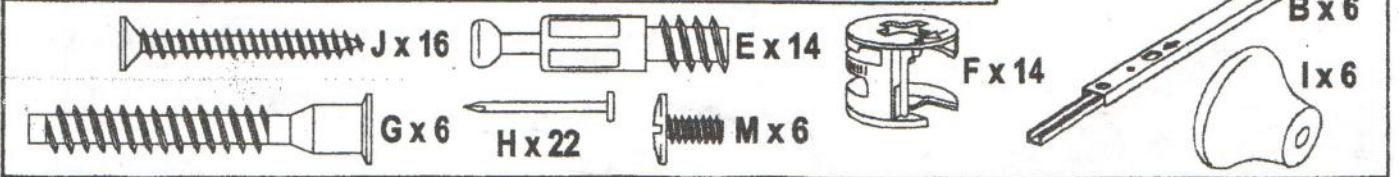
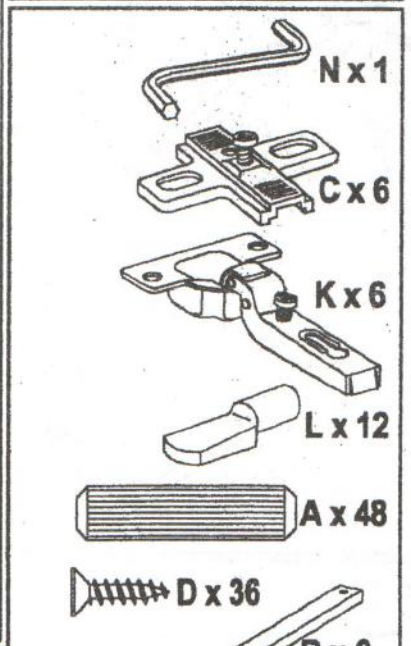
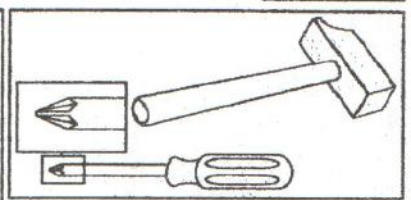
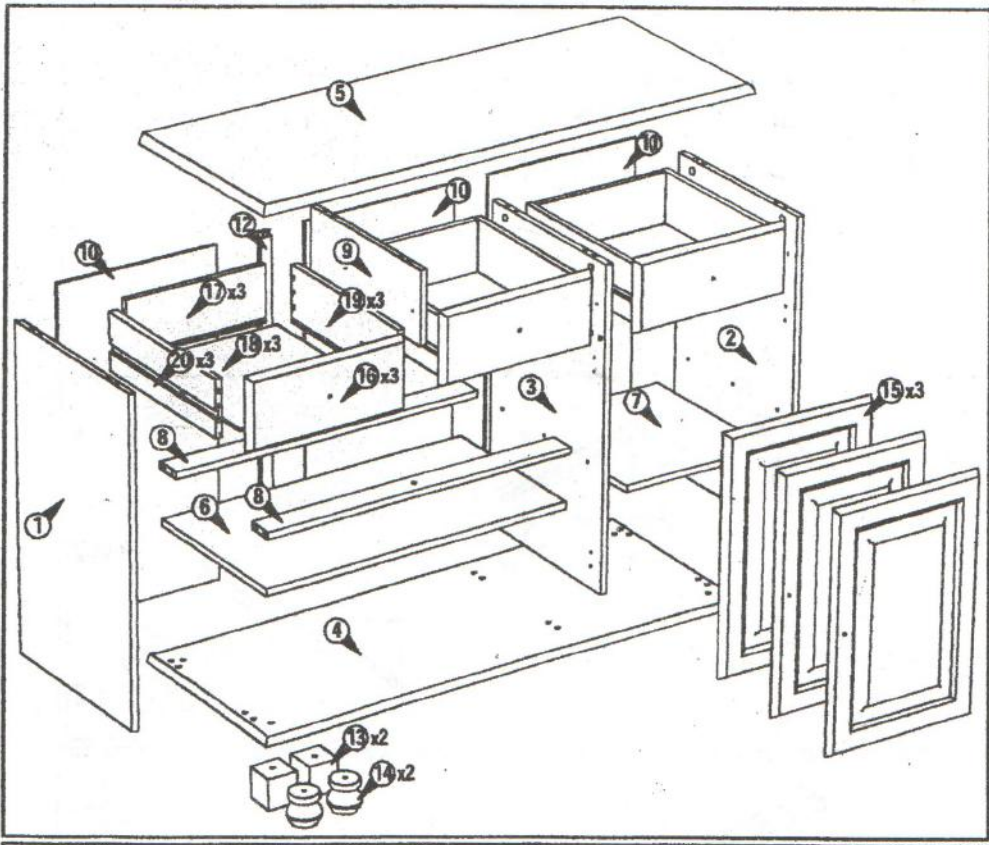
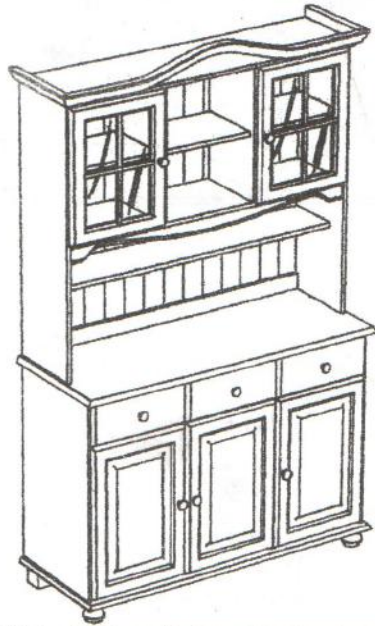

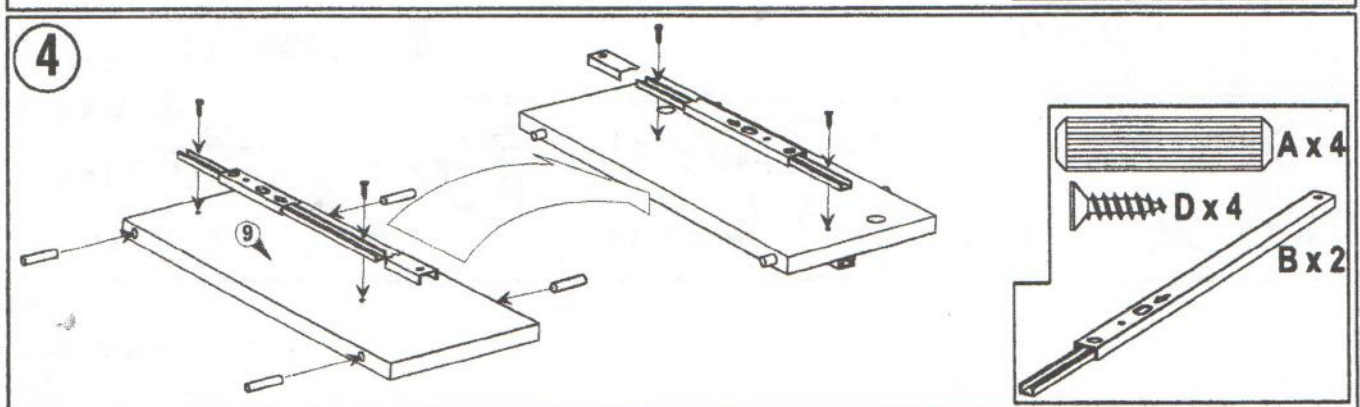
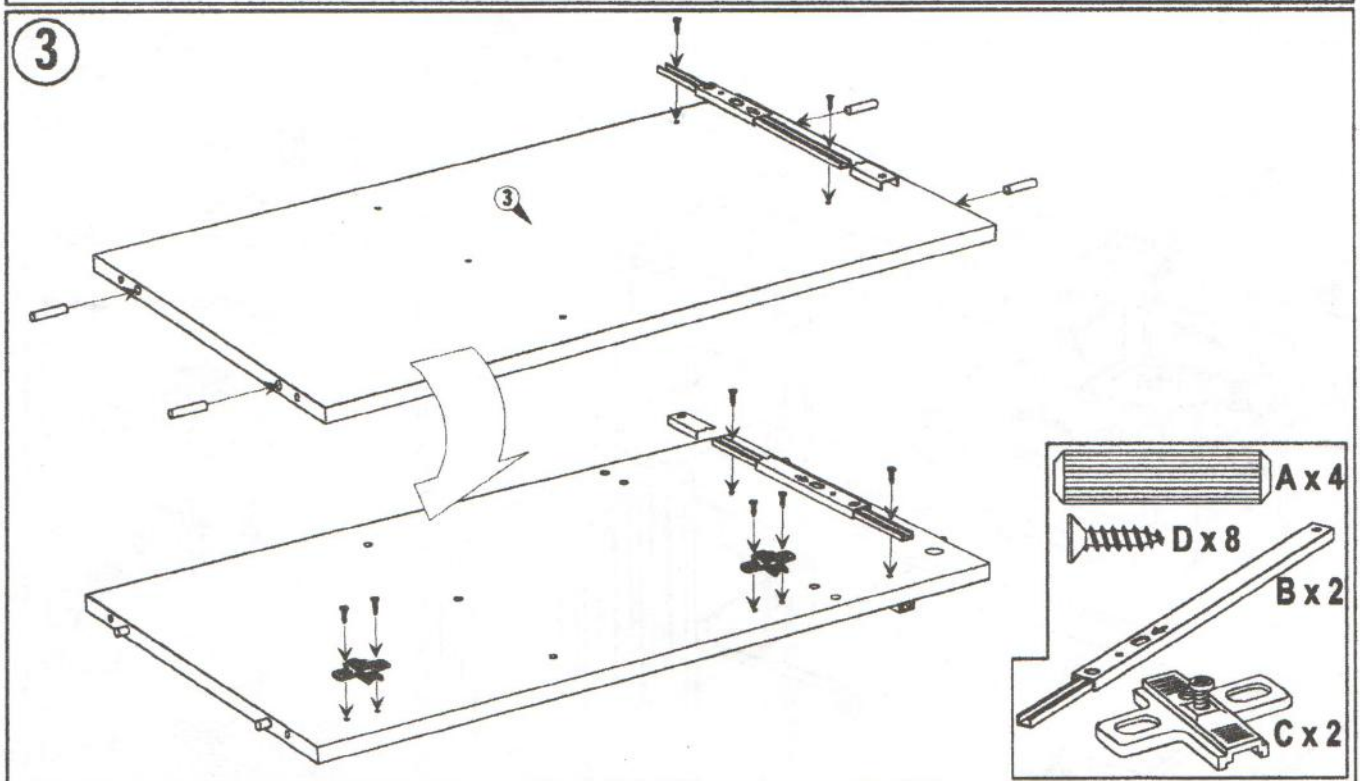
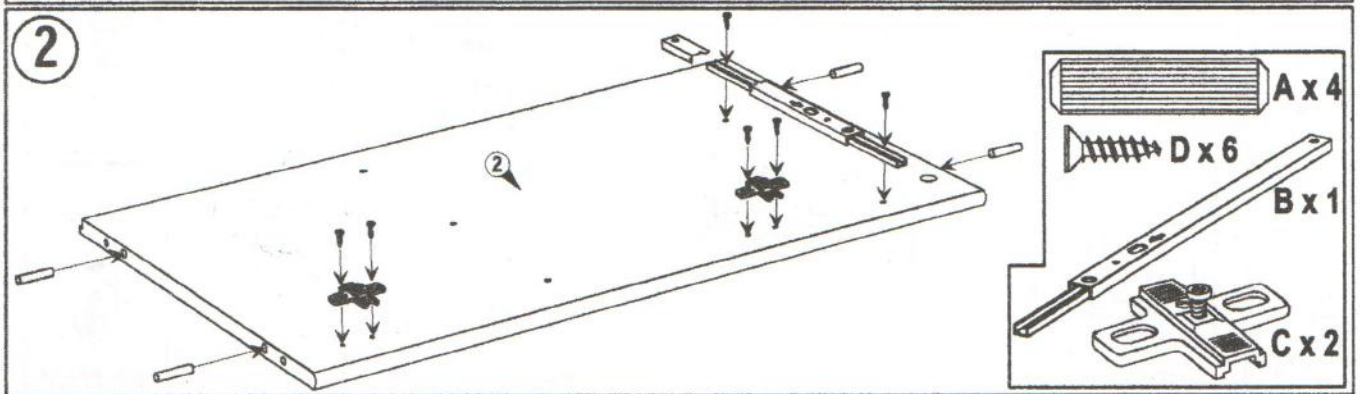
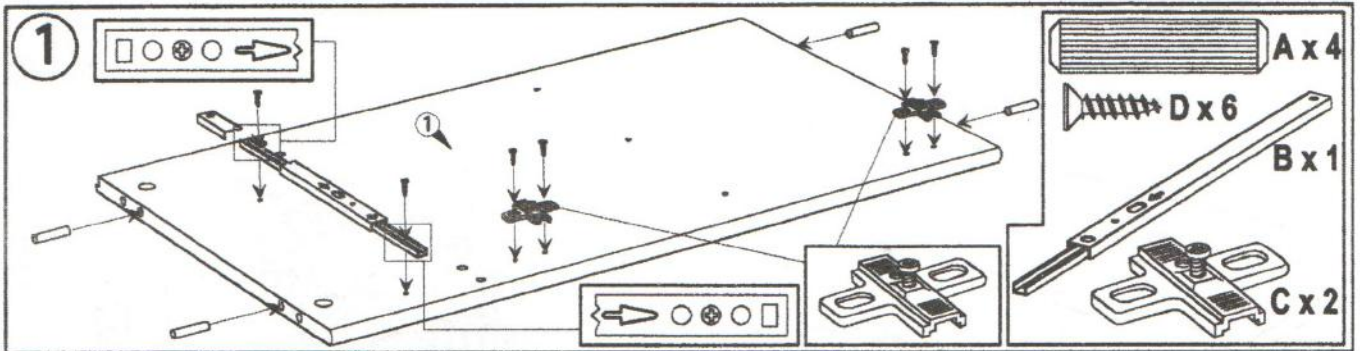

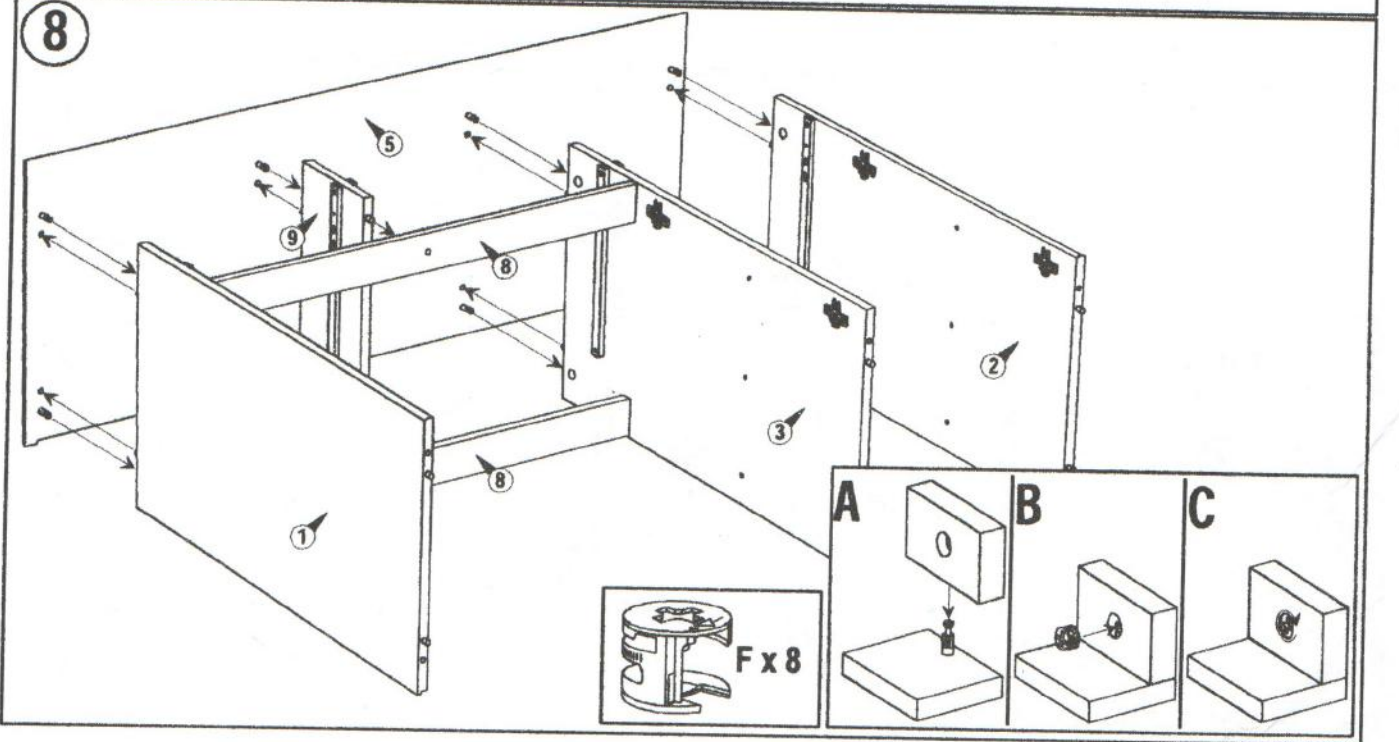
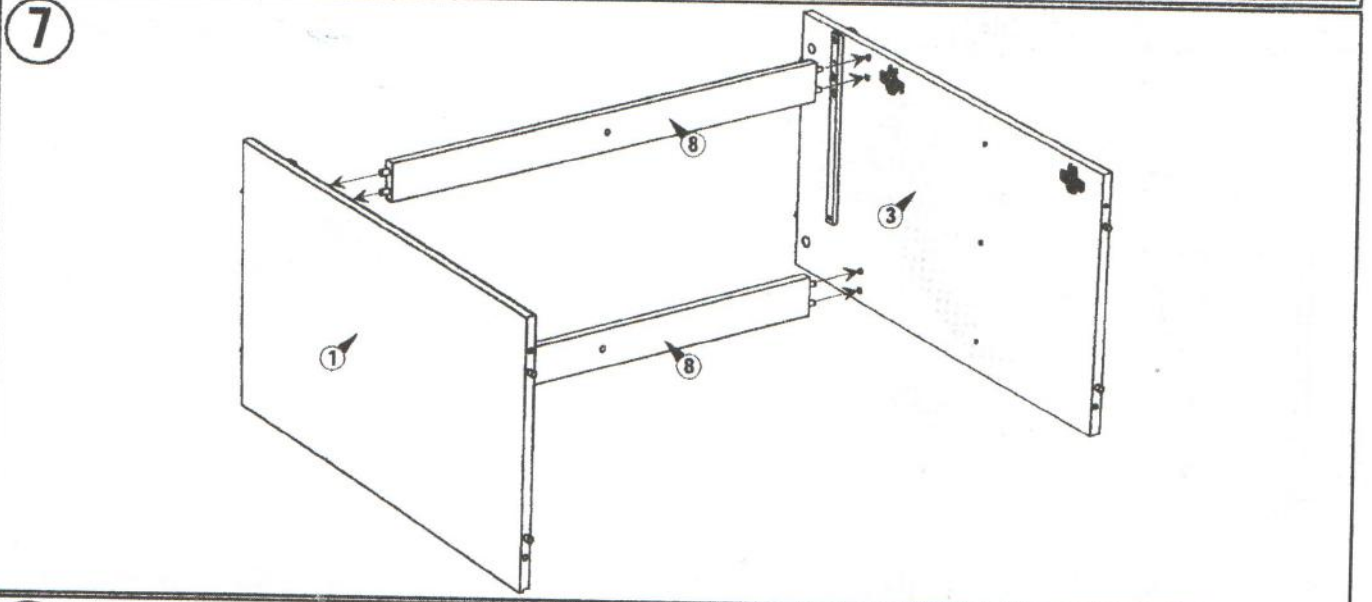
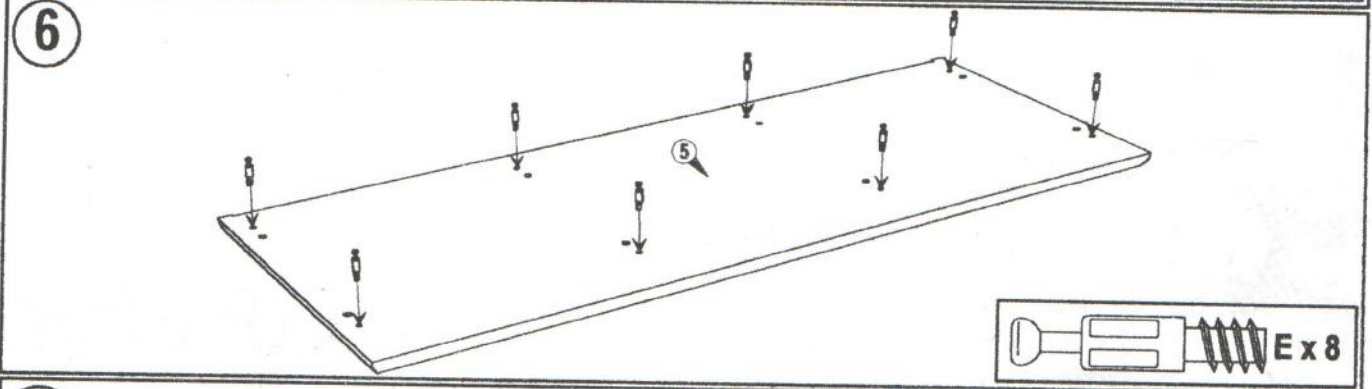
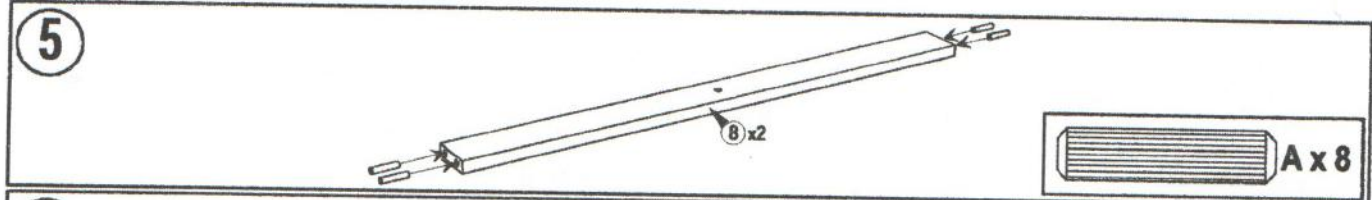

9

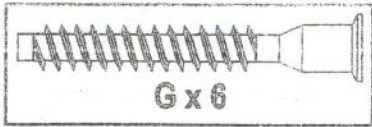
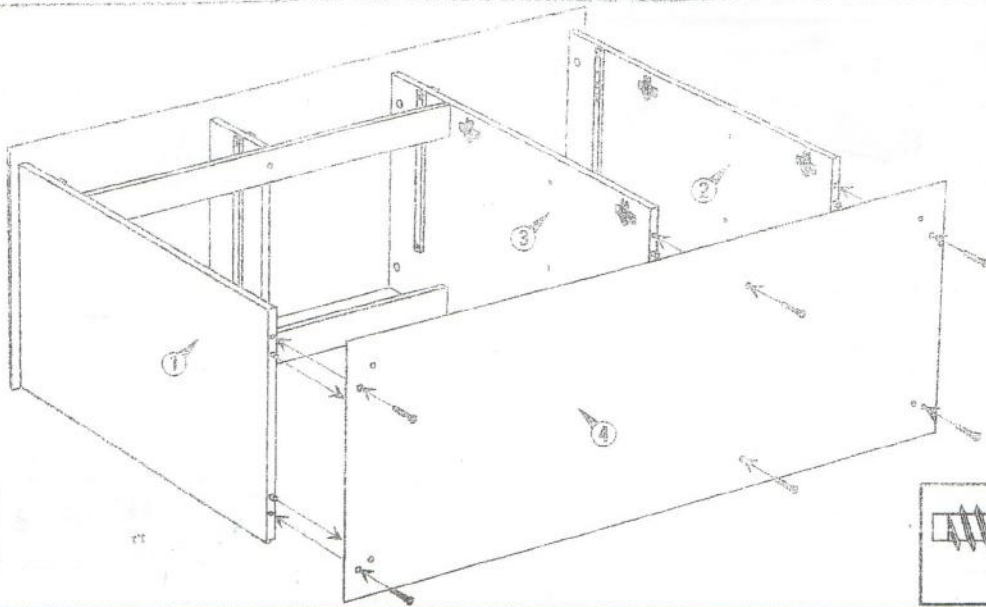

10

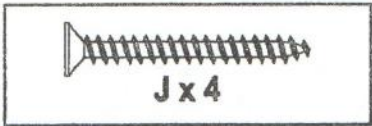
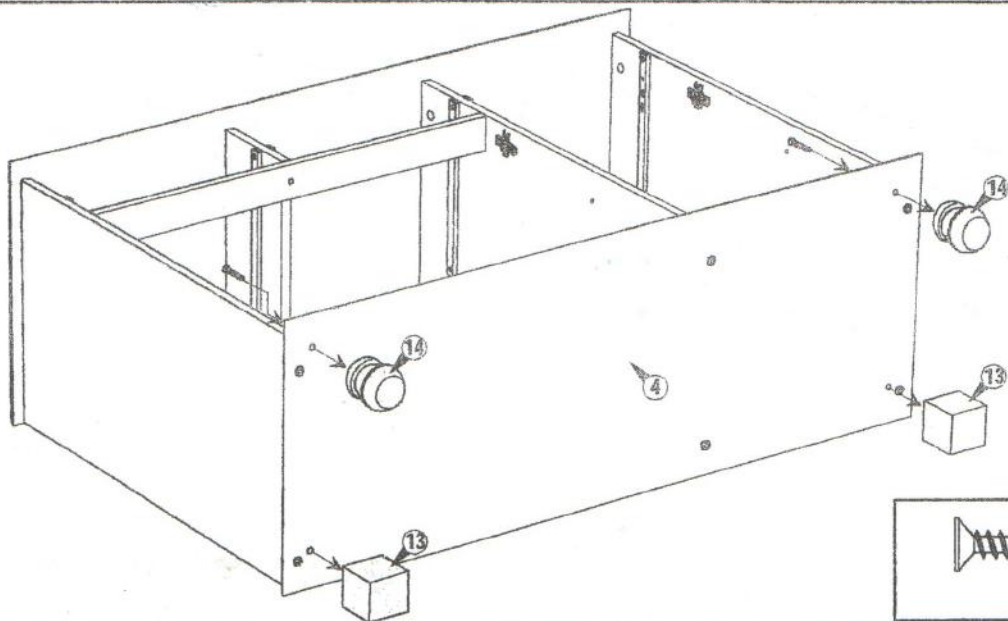

11

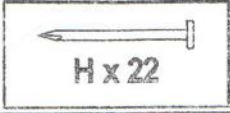
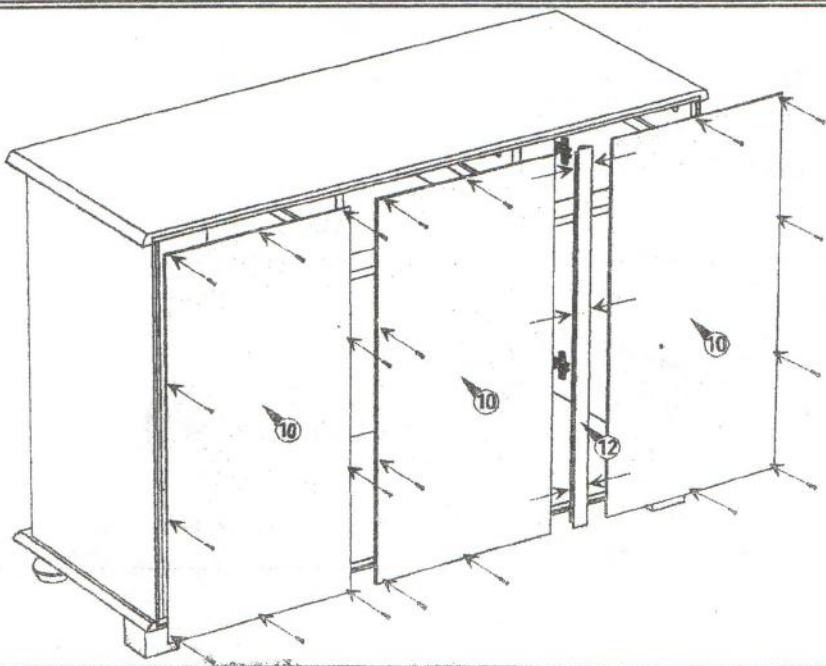

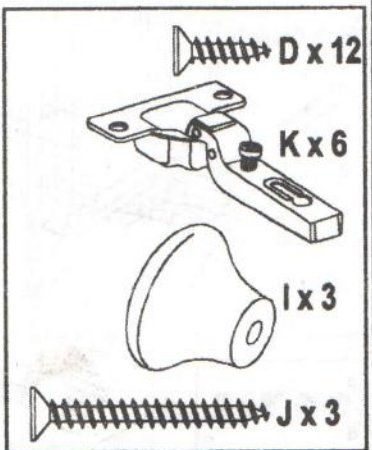
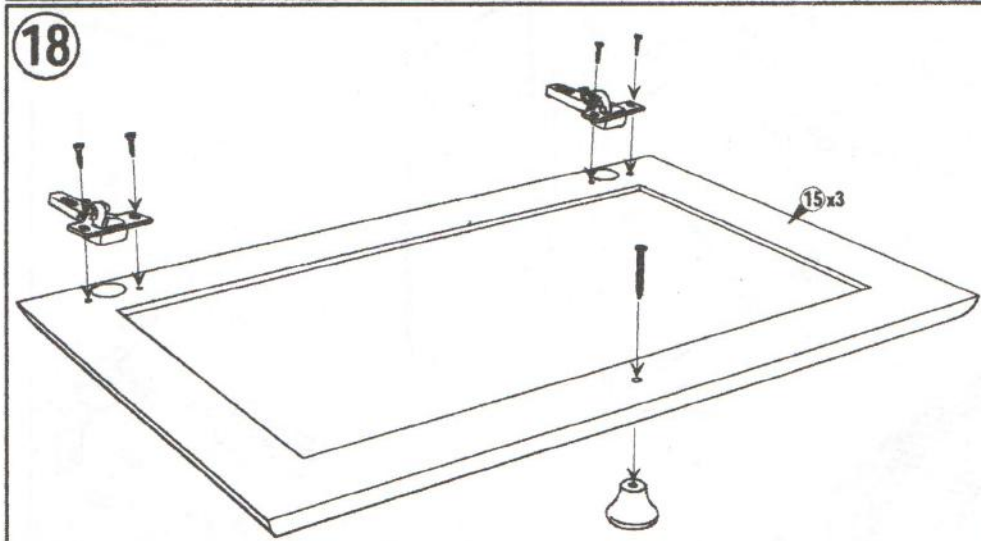
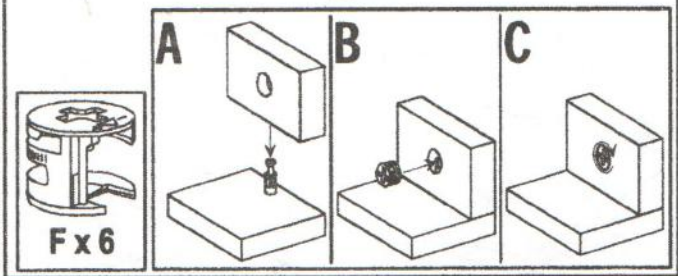
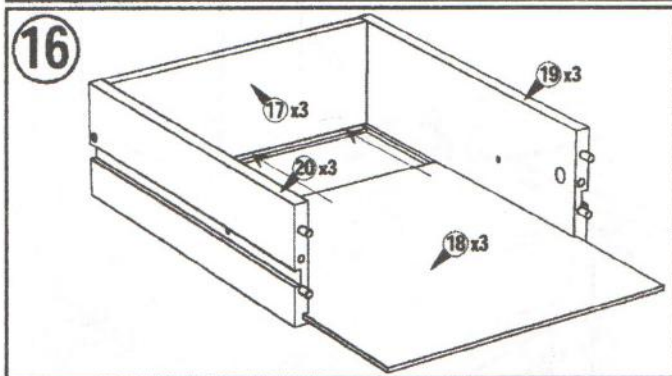
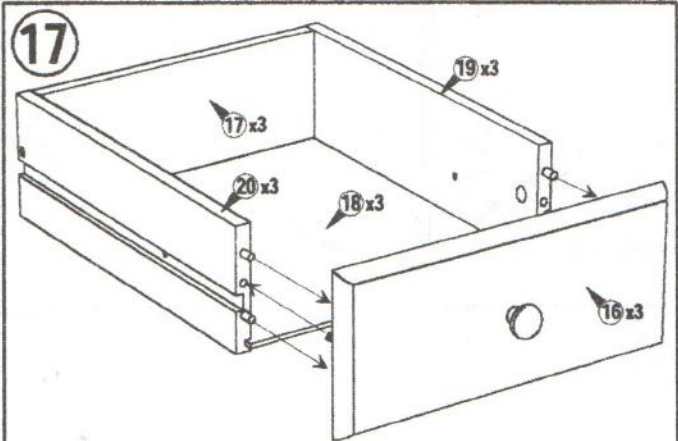
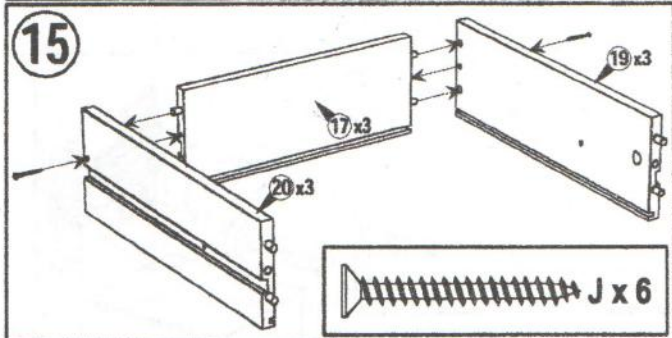
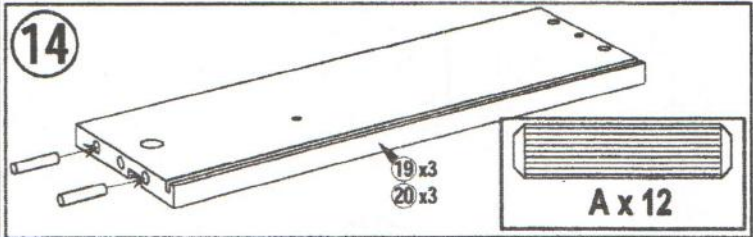
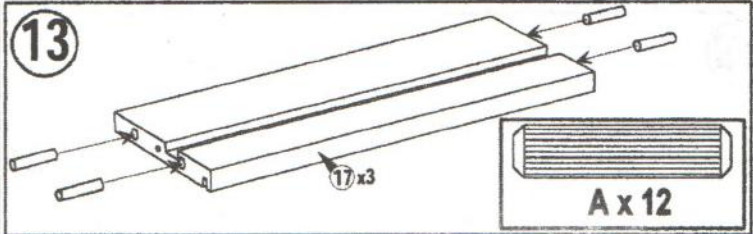
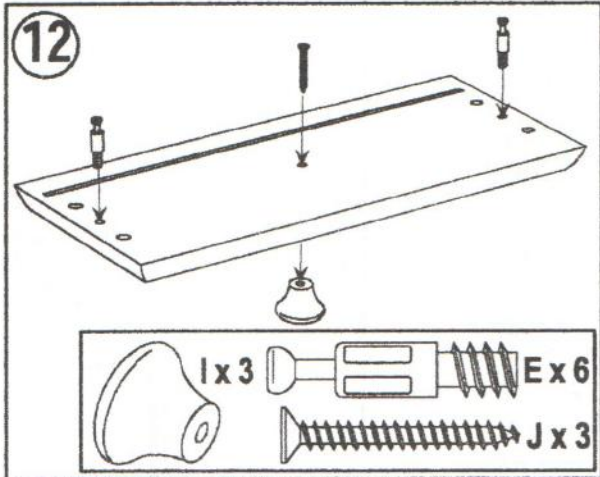

19

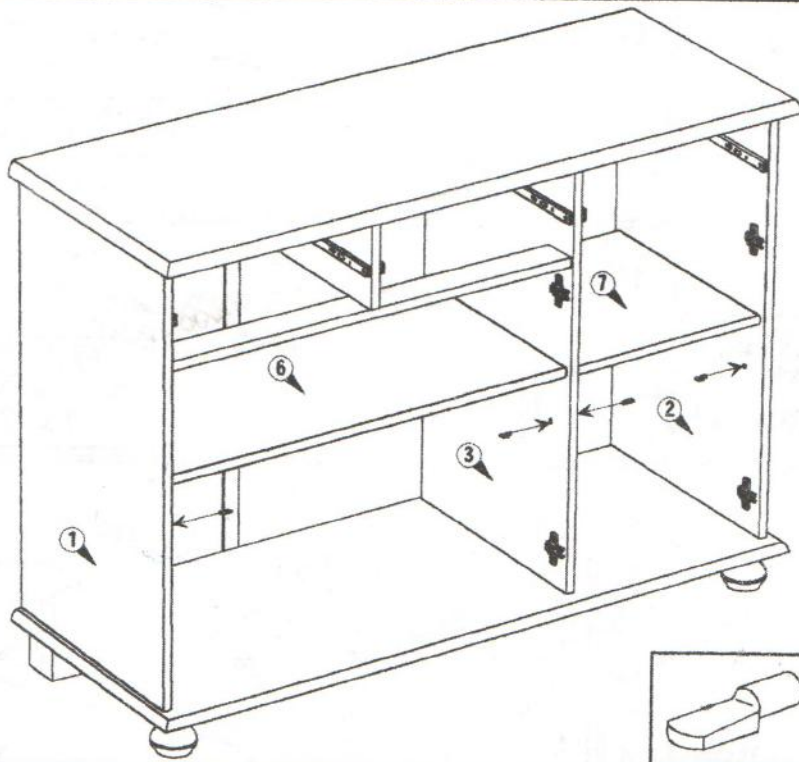

L x 12

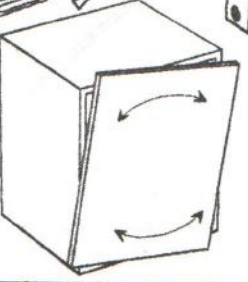
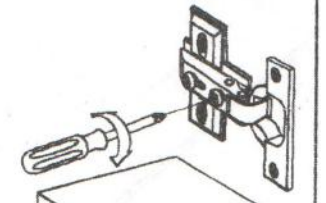
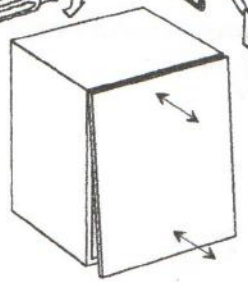
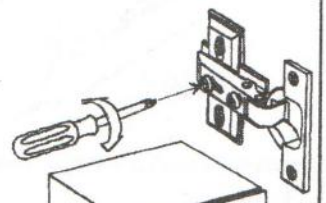
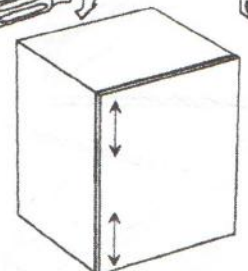
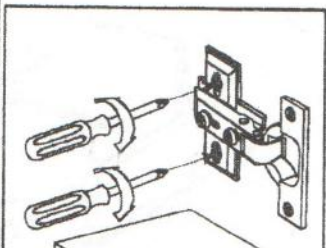

20

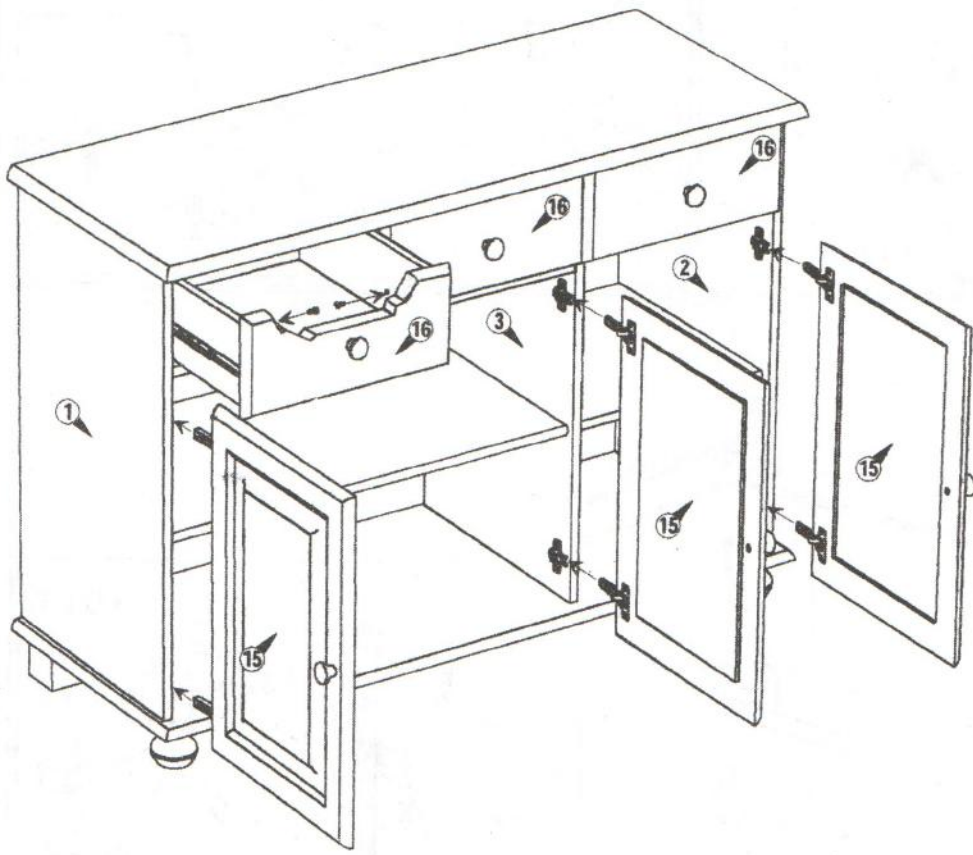

M x 6